

## COMPLEX ASSESSMENT OF STRUCTURAL SYSTEMS USED FOR HIGH-RISE BUILDINGS

Jolanta Tamošaitienė<sup>1</sup>, Ernestas Gaudutis<sup>2</sup>

<sup>1</sup>Department of Construction Technology and Management, Vilnius Gediminas Technical University, Saulėtekio al. 11, LT-10223 Vilnius, Lithuania

<sup>2</sup>Department of Architectural Engineering, Vilnius Gediminas Technical University, Sauletekio al. 11, LT-10223 Vilnius, Lithuania

E-mails: <sup>1</sup>jolanta.tamosaitiene@vgtu.lt (corresponding author); <sup>2</sup>ernestas.gaudutis@vgtu.lt

Received 4 Aug. 2012; accepted 21 Dec. 2012

**Abstract.** Today, increasingly more attention is given to reduction of the negative impacts of human activities on the surrounding environment during different stages of a building life cycle, which should be estimated during the design stage of the building. Selection of a structural system for a high-rise building remains a complex task that requires estimating a large amount of data such as structural system parameters, architectural solutions, engineering system requirements and construction process peculiarities. Decision-making problems in civil engineering often involve a complex decision-making process, in which multiple requirements and conditions have to be taken into consideration simultaneously. It means that such problems deal with sets of multiple criteria. The accuracy of performance measures in COPRAS (COmplex PROportional ASessment) method assumes direct and proportional dependence of the significance and utility degree of investigated alternatives on a system of criteria adequately describing the alternatives as well as on values and weights of the criteria. The research has concluded that the COPRAS-G method is appropriate for assessment of structural systems of high-rise buildings.

**Keywords:** MCDM, COPRAS-G, grey numbers, expert judgment, complex assessment, structural system, high-rise building.

**Reference** to this paper should be made as follows: Tamošaitienė, J.; Gaudutis, E. 2013. Complex assessment of structural systems used for high-rise buildings, *Journal of Civil Engineering and Management* 19(2): 305–317.

### 1. Introduction

Design of structural frames for high-rise buildings is one of the most complex design tasks in structural engineering. The design of a structural system must result in an appropriate solution. Besides, it must correspond to the construction and demolition processes. Hence, it is not only important to calculate loads that impact on the structural system of a building, but also estimate other factors, such as architectural solutions, engineering systems, construction process features and price. However, the design stage of a structural system often fails to apply various sustainable principles. There is a need to develop a method that would simultaneously reflect the impacts of decision-making on the cost and environment. Comparing the research results with sustainable design principles for selection of structural systems, this article investigates the effect of the existing sustainability requirements on structural systems of high-rise buildings and selection of materials. The decision-making process involves selection of the best alternative from several possible options. The selection is based on evaluation of relevant qualitative and quantitative criteria.

### 2. Complex assessment of structural systems used for high-rise buildings

Different normative documents and literature sources offer a wide choice of criteria that can be used to describe a high-rise building (Hang *et al.* 2012). Usually, a contemporary high-rise building is described in terms of metres above the ground or the number of storeys. Today, normative documents of different countries are one of the major sources for such information. Definitions of high-rise buildings differ from country to country (Parasonis, Gaudutis 2009) (Fig. 1). In Lithuania as well as in other countries, the definition of a high-rise building is determined by the ultimate height of the fire fighting equipment such as ladders and hoists. The Technical Construction Regulation STR 1.01.06:2002 “Structures of Exceptional Significance” of the Republic of Lithuania (2002) defines a high-rise building as a structure, the height of which from the ground to the highest point amounts to 30 metres. Another Technical Construction Regulation STR 2.02.01:2004 “Residential Buildings” (2004) contains a provision that describes a high-rise building as a structure with the upper storey including a

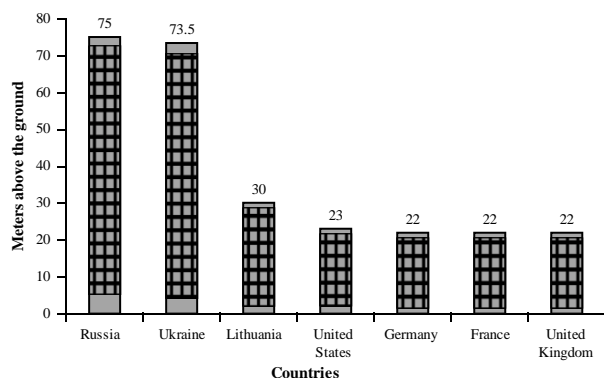

Fig. 1. Different definition of a high-rise building

mansard at the surface altitude of 26.5 metres and more. Consequently, the normative documents contain a contradiction, which impedes on the decision-making of local authorities. Rules on Preparation of Detailed Plans for Layout of High-Rise Buildings issued by the Ministry of Environment of the Republic of Lithuania define a high-rise building as a structure, the height of which from the mean altitude of the surface of the land plot to the highest point of the roof structure must be no less than 30 metres, unless a local municipal council regulates differently. In the city of Vilnius, a high-rise building must be at least 35 metres above the ground. This illustrates that different Lithuanian regulations contain small contradictions. As no uniform definition of a high-rise building exists, we defined our research object on the basis of the definition adopted by the Council of Vilnius.

The design of a building that would be efficient throughout the entire lifecycle requires rationality from the beginning to the end. All stages of a building lifecycle are closely interrelated; therefore, each and every of them need to be evaluated in order to achieve the maximum result (Fig. 2). The entire design of a building structure starts from selection of the key system. In the initial stage, it is sufficient to produce schematics of the structural system, regarding the type of structural elements, joints and materials. Usually, this task can be resolved on the basis of previous experience. To reduce the number of possible options, the approximate data on the use of different structural elements can be used as provided in tables below. The next step is the selection of the final structural system by modelling the load schemes for structural elements which are determined on the basis of normative documents and structural system calculation to select cross-sections of rational structural elements (Fig. 2).

The following basic requirements must be taken into account during the design of a structural system for a building (Ražaitis 2004):

### Strength

The strength of the structural system must be ensured during the design stage. It should be achieved by selecting the appropriate geometry of the structural system as well as the types of supports and joints of structural elements.

### Stability

A building structure can horizontally move or collapse under wind load. Thus, it is especially important to ensure the structural stability of a building. This stability depends on the weight of the structure as well as soil on which the foundation rests.

### Stiffness

It is the ability of a structure to resist deformation under loads; it can be ensured by increasing the cross-sectional dimensions of structural elements as well as stiffness of joints.

### Efficiency

Efficient selection of a structural system covers the overall rationality and functionality of the architectural and structural solution.

### Workability

Building process duration and economy in large part depend on workability of the selected structural system.

### Price

Cost has traditionally been considered the most important factor in the decision-making process (Shen *et al.* 2010). The total price depends on numerous factors such as the price for construction works that consist of materials and labour costs.

Analysis of a construction scheme allows estimating and simulating external loads and effects as well as identifying the limits. In structural system design, the next step is to find the best cross-sections of structural elements that would fully satisfy the requirements.

Many sustainable design principles have not been properly observed during the design stage of structural systems of different high-rise buildings. Project stakeholders fail to understand the importance of sustainable development principles for project feasibility studies (Shen *et al.* 2010). Mostly, this can be explained by an increase in the amount of required investments, which do not result in a financial benefit. The process of design not only requires estimating the construction and use stages,

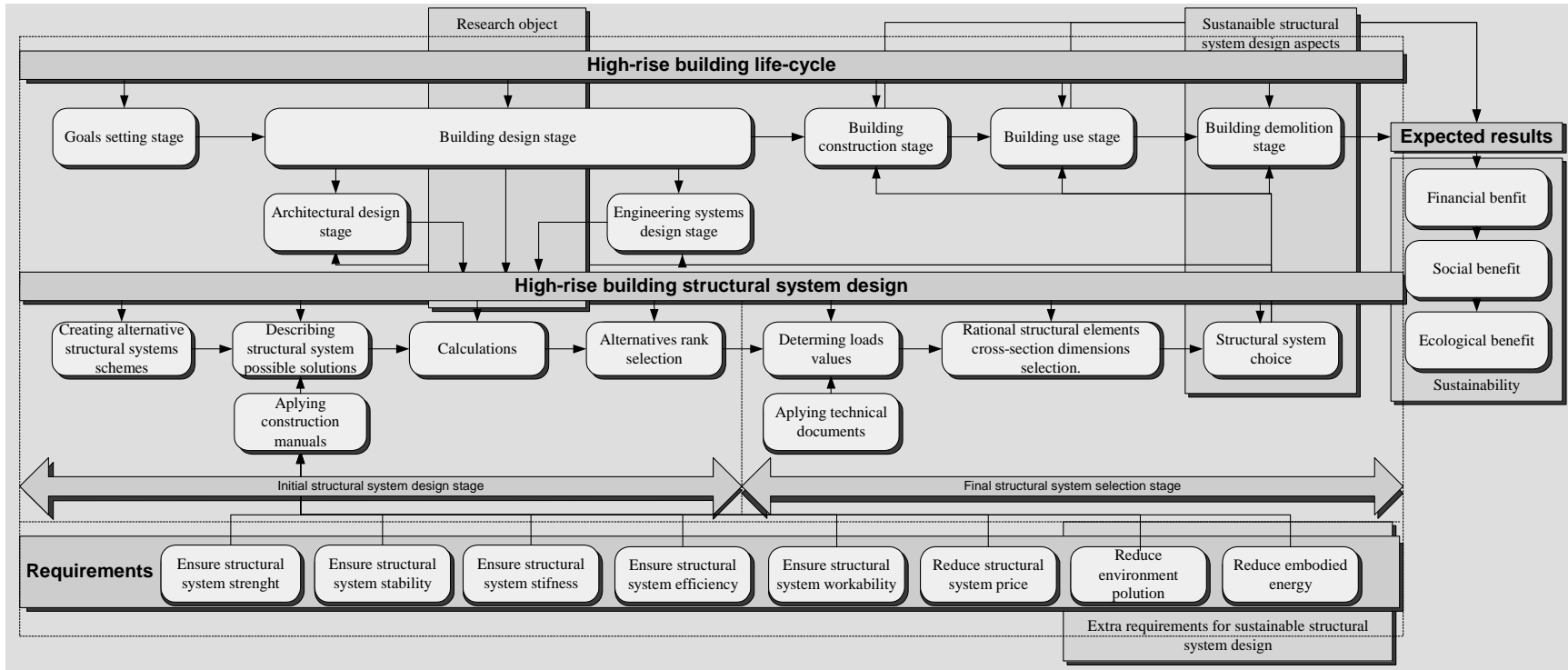

Fig. 2. Complex assessment model of a structural system used in a high-rise building

but also the demolition of the building. The main tasks of sustainable design are as follow:

- Reduction of environmental pollution;
- Reduction of energy consumption.

The building sector is one of the biggest energy consumers and carbon emitters (Zuo *et al.* 2012). The carbon footprint may be reduced by reusing the structural system, separate structural elements or materials of a building (Hong *et al.* 2012; Lee *et al.* 2012; Kua, Wong 2012). At the end of their useful life, construction materials could be reused (Fujita 2012; Berge 2012; Peças *et al.* 2013). Reuse refers to the ability to take parts of the structure and employ them elsewhere. However, such opportunity without the knowledge of the future demands is difficult to predict. The design stage of a structural system provides a possibility to take structural elements that remain at the end of a building lifecycle and turn them into other products (Ali, Moon 2007).

Buildings consume approximately 40 percent of total global energy: during the construction phase in the form of embodied energy and during the operation phase as operating energy (Dixit *et al.* 2010; Fiaschi *et al.* 2012). Without a doubt, energy efficiency is one of the most important aspects to be considered in a sustainable model of a building lifecycle. Embodied energy is expended in the processes of building material production (mining and manufacture), on-site delivery, construction and assembly on-site, renovation and final demolition (Dixit *et al.* 2010). Separate sustainable design concepts are based on reduction of embodied energy during different building lifecycle stages (Yuan *et al.* 2012; Dixit *et al.* 2012). Embodied energy accounts for a large proportion of lifecycle energy utilization in the building sector, and the estimation of this embodied energy is often difficult (Jiao *et al.* 2012; Hearn *et al.* 2012; Qian *et al.* 2012). Methodology aimed at minimising the embodied energy typically neglects the maximisation of the efficiency of the structural system. Although they do not play an active role in the energy design plan, the structural strategy and materials should be designed to respond to the overarching sustainability idea (Akadiri *et al.* 2012; Bojković *et al.* 2010).

A result is a triple bottom line, which refers to the three prongs of social, environmental and financial performance, which are directly tied to concept of complex assessment model and goal of sustainable development (Fig. 2).

### 3. Methodology

Complex assessment model of a structural system used in a high-rise building using MCDM (multi-criteria decision-making) remains somewhat different from the standard structural system assessment process (Fig. 3). In order to select the best alternative, it is necessary to have formed the decision matrix and to perform the multi-criteria analysis of the project.

MCDM refers to making preference decision on the alternatives in terms of multi-criteria. Typically, each alternative is evaluated on the established set/system of criteria.

Multi-criteria analysis is a popular tool used to resolve various economical, managerial, constructional and other types of problems. This method has been successfully used in research by various authors since 1987 to determine the quality criteria of significance in construction. The theoretical aspects and practical application of the expert judgment method have been investigated by many different areas shown in Table 1.

The main problem involving multi-criteria is often too complex for a decision-maker (Choi *et al.* 2012). The assessment of selection of an efficient structural system is made with the help of the COPRAS-G method with the values expressed in intervals. The idea of the COPRAS-G method comes from real conditions of decision-making and from applications of the grey systems theory.

The objective of this research is to demonstrate how a simulation can be used to reflect grey inputs, which allows more complete interpretation of model results. COPRAS method was developed by Zavadskas and Kaklauskas (1996). The COPRAS method determines a solution with the ratio to the rational solution.

### 4. Case study: selection of a sustainable structural system for a high rise building

The main problem is that different structural systems can be used for the same high-rise building. The research aims to select the most efficient structural system from several possible alternatives defined with the help of intervals. In Vilnius, a 24-storey administrative building was selected as a research object, which has a framed structural system, vertical concrete plate elements and a glass curtain wall.

The main steps of multi-criteria decision-making start with establishing evaluation criteria that relate the capabilities of the system to the goals. First, possible options of the structural system of a high-rise building have to be selected on the basis of the shape and height of the building. Possible structural system alternatives are provided in Table 2 and Figs 4, 5. On this building design stage we do not have precise building structural elements sizes therefore for different structural systems comparison we use approximate data taken from manuals for structural engineers which data expressed in intervals (Taranath 1998; Ražaitis 2004; Parasonis 2008). According to this data were calculated amounts of wastes and energy, building design and construction price. Next, set of alternatives have to be developed to reach the goals. In this case, it is possible to use a methodology that allows making a decision on the basis of process-related qualitative and quantitative criteria. In order to select

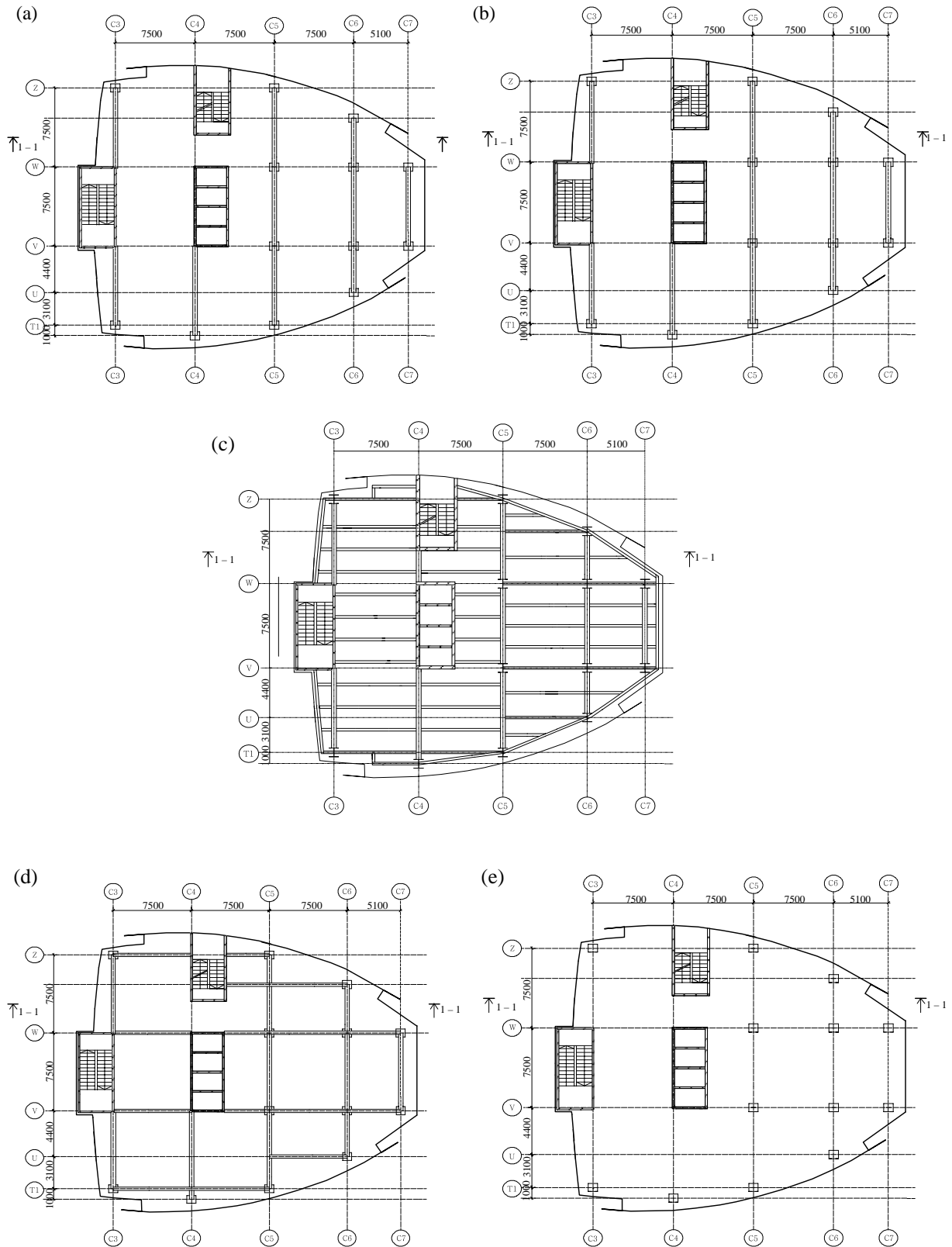

Fig. 3. Complex assessment model of a structural system used in a high-rise building

the best alternative, it is necessary to create the decision-making matrix and to perform the multi-criteria analysis of the project, accepting one alternative as the optimal one (Kendall 1970).

The expert judgment method was used to determine the significance of quantitative criteria and form the order of priority. The task had to be completed using various criteria of effectiveness with different

**Table 1.** Use of MCDM in the analysis of a building life cycle

Stage	Methods	Article title and authors	Results of the calculation
Building design	AHP (Analytic Hierarchy Process)	Multi-criteria Optimization System for Decision-making in Construction design and management (Turskis <i>et al.</i> 2009)	Alternatives importance relative to one other
	Expert judgment method	Assessment of the indoor environment of dwelling houses by applying the COPRAS-G method: Lithuania case study (Zavadskas <i>et al.</i> 2011)	In determining the significance of quantitative indicators, the order of priority was arranged.
	COPRAS (COmplex PROportional ASsessment of alternatives)	Passive house model for quantitative and qualitative analyses and its intelligent system (Kaklauskas <i>et al.</i> 2012)	The optimal alternative is at the minimum distance from the ideal solution while the maximum distance from the ideal solution means the worst option.
	COPRAS-G (COmplex PROportional ASsessment of alternatives)	An assessment of sustainable housing affordability using a multiple criteria decision-making method (Mulliner <i>et al.</i> 2013) Assessment of the indoor environment of dwelling houses by applying the COPRAS-G method: Lithuania case study (Zavadskas <i>et al.</i> 2011)	
Building construction	SAW (Simple Additive Weighting) method	Safety of technological projects using multi-criteria decision-making methods (Dėjus 2011)	The order of priority of alternatives
	TOPSIS (Technique for Order Preference by Similarity to Ideal Solution)	Complex estimation and choice of resource saving decisions in construction (Zavadskas 1987) Groundwater quality assessment based on rough sets of criteria reduction and TOPSIS method in a semi-arid area China (Li <i>et al.</i> 2012)	
	PROMETHEE (The Preference Ranking Organization MeTHod for Enrichment Evaluations)	Selection of logistic service provider using fuzzy PROMETHEE for a cement industry (Gupta <i>et al.</i> 2012) PROMETHEE with Precedence Order in the Criteria (PPOC) as a New Group Decision-making Aid: An Application in Urban Water Supply Management (Roozbahani <i>et al.</i> 2012)	Prove the significance of each criterion and define it on the scale of an interval.
	Expert judgment method	Complex estimation and choice of resource saving decisions in construction (Zavadskas 1987) Multiple criteria evaluation of buildings (Zavadskas, Kaklauskas 1996) Risk assessment of construction projects (Zavadskas <i>et al.</i> 2010) Application of Expert Evaluation Method to Determine the Importance of Operating Asphalt Mixing Plant Quality Criteria and Rank Correlation (Sivilevicius 2011)	In determining the significance of quantitative indicators, the order of priority was arranged
	COPRAS (COmplex PROportional ASsessment of alternatives)	Multiple criteria evaluation of buildings (Zavadskas, Kaklauskas 1996) COPRAS based comparative analysis of the European country management capabilities within the construction sector in the time of crisis (Kildienė <i>et al.</i> 2011)	Optimal alternative is the minimum distance from ideal solution and maximum distance from ideal solution is the worst

Table 1 (Continued)

Stage	Methods	Article title and authors	Results of the calculation
	COPRAS-G	<p>Materials selection using complex proportional assessment and evaluation of mixed data methods (Chatterjee <i>et al.</i> 2011)</p> <p>Material selection using preferential ranking methods (Chatterjee, Chakraborty 2012)</p> <p>Evaluating the construction methods of cold-formed steel structures in reconstructing the areas damaged in natural crises, using the methods AHP and COPRAS-G (Bitarafan <i>et al.</i> 2012)</p> <p>Owner preferences regarding renovation measures – the demonstration of using multi-criteria decision-making (Medineckienė, Björk 2011)</p> <p>Multiple criteria decision support system for assessment of projects managers in construction (Zavadskas <i>et al.</i> 2012)</p> <p>Risk assessment of construction projects (Zavadskas <i>et al.</i> 2010)</p>	The optimal alternative is at the minimum distance from the ideal solution while the maximum distance from the ideal solution means the worst option.
Building renovation	<p>SAW (Simple Additive Weighting) method</p> <p>TOPSIS (Technique for Order Preference by Similarity to Ideal Solution)</p>	Multi-criteria assessment of alternatives for built and human environment renovation (Tupenaite <i>et al.</i> 2010)	<p>The order of priority of alternatives</p> <p>The order of priority of alternatives</p>
Building life-cycle	<p>AHP (Analytic Hierarchy Process)</p> <p>COPRAS (COMplex PROportional ASsessment of alternatives)</p>	Life-Cycle Analysis of A Sustainable Building, Applying Multi-Criteria Decision-making Method (Medineckienė <i>et al.</i> 2011)	<p>Alternatives importance relative to one other</p> <p>Optimal alternative is the minimum distance from ideal solution and maximum distance from ideal solution is the worst</p>

**Table 2.** Establishment of weight of structural system criteria

Experts	Effective structural system height (m)	Floor-to-floor height (m)	Building frame lengthwise columns step (m)	Building frame transverse columns step (m)	Slab span length (m)	Building design price (€/m <sup>3</sup> )	Terms of performance (m <sup>3</sup> /w.d.)	Building construction price (€/m <sup>3</sup> )	Embodied energy (kJ/kg)	Embodied carbon (kgCO <sub>2</sub> /kg)	Building demolition price (€/m <sup>3</sup> )
Expert 1	11	10	5	6	9	4	7	8	3	2	1
Expert 2	11	10	7	8	6	4	5	9	3	1	2
Expert 3	10	9	6	7	5	4	8	11	3	2	1
Expert 4	11	10	5	6	8	4	7	9	3	2	1
Expert 5	8	7	9	10	11	4	6	5	3	2	1
Expert 6	8	7	10	11	9	4	5	6	3	2	1
Expert 7	11	10	8	7	9	4	6	5	3	2	1
Expert 8	11	10	6	7	5	4	8	9	3	1	2
Expert 9	11	10	7	8	6	4	5	9	3	2	1
Expert 10	11	10	5	6	8	4	7	9	3	2	1
Expert 11	11	10	8	7	9	4	6	5	3	2	1
Expert 12	10	9	6	7	5	4	8	11	3	1	2
Average rank	10.33	9.33	6.83	7.50	7.50	4.00	6.50	8.00	3.00	1.83	1.17
Sum of ranks	124	112	82	90	90	48	78	96	36	22	14
Order of priority	1	2	6	5	4	8	7	3	9	10	11
Significance	0.098	0.097	0.090	0.088	0.090	0.094	0.089	0.098	0.095	0.086	0.084

Concordation ratio  $W=0.846$ .

Sum of the deviations square  $S=13400$ . Significance of the concordation ratio  $\chi=101.52$ .

Significance of the concordation ratio  $\chi_{z,v}=23.210$ .

If  $\chi^2 > \chi_{z,v}^2$  expert opinion consistent and criteria weights are recommended to apply calculation.



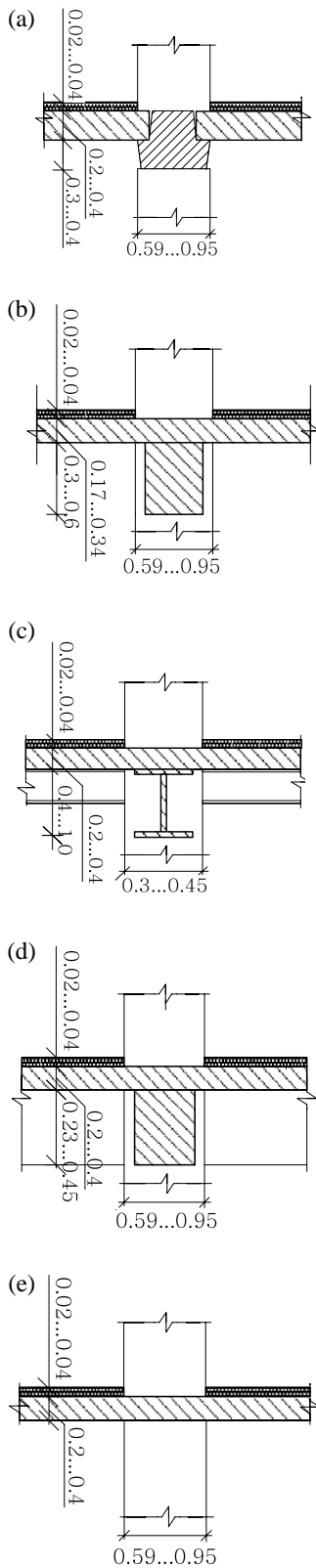

**Fig. 4.** Possible alternatives for a structural system of a high-rise building: a) semi-rigid frame (sectional monolithic concrete) –  $A_1$ ; b) semi-rigid frame (monolithic concrete) –  $A_2$ ; c) semi-rigid frame (steel beams and columns, concrete span) –  $A_3$ ; d) rigid frame (monolithic concrete) –  $A_4$ ; e) rigid frame without beams (monolithic concrete) –  $A_5$

dimensions, significances and direction of optimization. The criteria define the positive and the negative characteristics of an object under investigation. A survey was made to ask experts to prioritize 11 criteria (the rating scale ranged from 1 to 11, where 11 meant “very important” and 1 meant “not important at all”):

- $x_1$  – effective height of the structural system (storeys);
- $x_2$  – typical floor-to-floor height (m);
- $x_3$  – lengthwise step of a column (m);
- $x_4$  – transverse step of a column (m);
- $x_5$  – length of a slab span (m);
- $x_6$  – price for the design of the structural system (€/m<sup>3</sup>);
- $x_7$  – terms of performance (m<sup>3</sup>/w.d.);
- $x_8$  – price for the construction of the building (€/m<sup>3</sup>);
- $x_9$  – embodied energy (kJ/kg);
- $x_{10}$  – embodied carbon (kgCO<sub>2</sub>/kg);
- $x_{11}$  – price for the demolition of the building (€/m<sup>3</sup>).

The team of 12 experts was comprised of civil engineers with a long-term experience in design of structural systems for high-rise buildings. The experts had to use their knowledge, experience and intuition and rate criteria of effectiveness starting with the most important ones. The optimization directions of selected criteria and expert priorities were given to structural systems of the high-rise building on the basis of the data, important parameters of which are given in Table 3.

Out of all possible options, the final alternative was selected with the help of the COPRAS-G method. On the basis of the efficiency priority of alternatives, a rank  $R$  for each alternative was established (Table 4). According to calculation results, alternative  $A_1$  was identified as the best one. The first alternative was also the best in terms of its utility degree that equals 100%. The second alternative with the utility degree of 77.2% was ranked second. The fourth alternative with the utility degree of 76.9% was ranked third. The fifth alternative with the utility degree of 69.0% was ranked fourth. The third alternative with the utility degree of 51.9% was the worst choice and ranked fifth. The vector of optimality criterion values was  $N_j = [100; 77.2; 51.9; 76.9; 69.0]$ . The ranking of alternatives according to the results of the research are presented in the Figure 5.

According to the vector  $N$  the alternatives ranked as follows:  $A_1 > A_2 > A_4 > A_5 > A_3$ .

According to the analysis results, structural engineers can choose the most effective alternative. The next step in the design of the structural system of a building should be the development of a calculation scheme for a selected structural system that would help determining loads and impacts as well as assessing the precise of geometrical characteristics of structural elements.



**Table 4.** Calculation results

Alternative No	Total sum of maximizing normalized criteria $P_i$	Total sum of minimizing normalized criteria $R_i$	Alternative's significance $Q_i$	Alternative's degree of efficiency $N_i$	Rank $R_i$
1	0.143	0.141	0.533	100.00	1
2	0.159	0.217	0.412	77.18	2
3	0.164	0.487	0.277	51.92	5
4	0.132	0.198	0.410	76.90	3
5	0.129	0.230	0.368	69.02	4

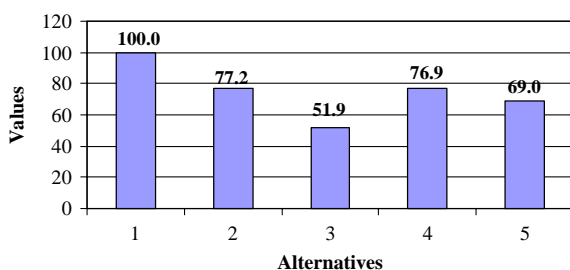
**Fig. 5.** Ranking of alternatives

## 5. Discussion

In the future, this academic task could be transformed into an expert system, which – based on knowledge and applied analysis rules – would make it possible to identify certain field problems. It could transform into a practically used structural analysis and design programs. Besides, it could be used by structural engineers as yet another step toward automated design of a structural system and the whole building based on the life-cycle model as well as, possibly for the development of artificial intelligence.

## 6. Conclusions

The research showed that the integration of expert judgment and COPRAS-G methods can be used by structural engineers during the design stage of a building to select the most efficient structural system, when initial data expressed in grey numbers.

The selection of the structural system is approximate and the final decision can be taken after the final selection of the best structural system, taking into account structure affecting load values and selection of geometrical characteristics of structural elements. This methodology could help to reduce the number of options on the basis of a large number of criteria.

A case study demonstrated that contemporary environmental aspects have little importance for the design of structural systems.

The analysis of the problem on the basis of the selected criteria demonstrated that the semi-rigid frame  $A_1$ , which consists of prefabricated reinforced

concrete products, is more preferable than the remaining four alternatives under investigation.

## References

- Akadiri, P. O.; Chinyio, E. A.; Olomolaiye, P. O. 2012. Design of a sustainable building: a conceptual framework for implementing sustainability in the building sector, *Buildings* 2(2): 126–152.  
<http://dx.doi.org/10.3390/buildings2020126>
- Ali, M. M.; Moon, K. S. 2007. Structural developments in tall buildings: current trends and future prospects, *Architectural Science Review* 50(3): 205–223.  
<http://dx.doi.org/10.3763/asre.2007.5027>
- Bitarafan, M.; Hashemkhani Zolfani, S.; Arefi, S. L.; Zavadskas, E. K. 2012. Evaluating the construction methods of cold-formed steel structures in reconstructing the areas damaged in natural crises, using the methods AHP and COPRAS-G, *Archives of Civil and Mechanical Engineering* 12(3): 360–367.  
<http://dx.doi.org/10.1016/j.acme.2012.06.015>
- Berge, B. 2012. *The ecology of building materials*. Routledge. 448 p.
- Bojković, N.; Anić, I.; Pejčić-Tarle, S. 2010. One solution for cross-country transport-sustainability evaluation using a modified ELECTRE method, *Ecological Economics* 69(5): 1176–1186.  
<http://dx.doi.org/10.1016/j.ecolecon.2010.01.006>
- Chatterjee, P.; Chakraborty, S. 2012. Material selection using preferential ranking methods, *Materials & Design* 35: 384–393.  
<http://dx.doi.org/10.1016/j.matdes.2011.09.027>
- Chatterjee, P.; Athawale, V. M.; Chakraborty, S. 2011. Materials selection using complex proportional assessment and evaluation of mixed data methods, *Materials & Design* 32(2): 851–860.  
<http://dx.doi.org/10.1016/j.matdes.2010.07.010>
- Choi, W.; Joe, J.; Kwak, Y.; Huh, J.-H. 2012. Operation and control strategies for multi-storey double skin facades during the heating season, *Energy and Buildings* 49: 454–465.  
<http://dx.doi.org/10.1016/j.enbuild.2012.02.047>
- Déjus, T. 2011. Safety of technological projects using multi-criteria decision making methods, *Journal of Civil Engineering and Management* 17(2): 177–183.
- Dixit, M. K.; Fernández-Solís, J. L.; Lavy, S.; Culp, C. H. 2012. Need for an embodied energy measurement protocol for buildings: a review paper, *Renewable & Sustainable Energy Review* 16(6): 3730–3743.  
<http://dx.doi.org/10.1016/j.rser.2012.03.021>

- Dixit, M. K.; Fernández-Solís, J. L.; Lavy, S.; Culp, C. H. 2010. Identification of parameters for embodied energy measurement: a literature review, *Energy and Buildings* 42(8): 1238–1247. <http://dx.doi.org/10.1016/j.enbuild.2010.02.016>
- Fiaschi, D.; Bandinelli, R.; Conti, S. 2012. A case study for energy issues of public buildings and utilities in a small municipality: investigation of possible improvements and integration with renewables, *Applied Energy* 97: 101–114. <http://dx.doi.org/10.1016/j.apenergy.2012.03.008>
- Fujita, M. 2012. Reuse system of building steel structures – structural performance of reusable members and practical examples, *Key Engineering Materials* 517: 513–521. <http://dx.doi.org/10.4028/www.scientific.net/KEM.517.513>
- Gupta, R.; Sachdeva, A.; Bhardwaj, A. 2012. Selection of logistic service provider using fuzzy PROMETHEE for a cement industry, *Journal of Manufacturing Technology Management* 23(7): 899–921. <http://dx.doi.org/10.1108/17410381211267727>
- Hang, J.; Li, Y.; Sandberg, M.; Buccolieri, R.; Di Sabatino, S. 2012. The influence of building height variability on pollutant dispersion and pedestrian ventilation in idealized high-rise urban areas, *Building and Environment* 56: 346–360. <http://dx.doi.org/10.1016/j.buildenv.2012.03.023>
- Hearn, G.; Wise, D.; Hart, A.; Morgan, C. 2012. Assessing the potential for future first-time slope failures to impact the oil and gas pipeline corridor through the Makarov Mountains, Sakhalin Island, Russia, *Quarterly Journal of Engineering Geology & Hydrogeology* 45(1): 79–88. <http://dx.doi.org/10.1144/1470-9236/10-033>
- Hong, T.; Ji, C.; Park, H. 2012. Integrated model for assessing the cost and CO<sub>2</sub> emission (IMACC) for sustainable structural design in ready-mix concrete, *Journal of Environmental Management* 103: 1–8. <http://dx.doi.org/10.1016/j.jenvman.2012.02.034>
- Jiao, Y.; Lloyd, C. R.; Wakes, S. J. 2012. The relationship between total embodied energy and cost of commercial buildings, *Energy and Buildings* 52: 20–27. <http://dx.doi.org/10.1016/j.enbuild.2012.05.028>
- Kaklauskas, A.; Rute, J.; Zavadskas, E. K.; Daniunas, A.; Pruskus, V.; Bivainis, J.; Gudauskas, R.; Plakys, V. 2012. Passive house model for quantitative and qualitative analyses and its intelligent system, *Energy and Buildings* 50: 7–18. <http://dx.doi.org/10.1016/j.enbuild.2012.03.008>
- Kendall, M. G. 1970. *Rank correlation methods*. 4th ed. London: Griffin. p 365.
- Kildienė, S.; Kaklauskas, A.; Zavadskas, E. K. 2011. COPRAS based comparative analysis of the European country management capabilities within the construction sector in the time of crisis, *Journal of Business Economics and Management* 12(2): 417–434. <http://dx.doi.org/10.3846/16111699.2011.575190>
- Kua, H. W.; Wong, C. L. 2012. Analyzing the life cycle greenhouse gas emission and energy consumption of a multi-storied commercial building in Singapore from an extended system boundary perspective, *Energy and Buildings* 51: 6–14. <http://dx.doi.org/10.1016/j.enbuild.2012.03.027>
- Lee, S.; Joo, J.; Kim, J. T.; Kim, S. 2012. An analysis of the CO<sub>2</sub> reduction effect of a column-beam structure using composite precast concrete members, *Indoor and Built Environment* 21(1): 150–162. <http://dx.doi.org/10.1177/1420326X11423162>
- Li, P.; Wu, J.; Qian, H. 2012. Groundwater quality assessment based on rough sets attribute reduction and TOPSIS method in a semi-arid area, China, *Environmental Monitoring and Assessment* 184(8): 4841–4854. <http://dx.doi.org/10.1007/s10661-011-2306-1>
- Medineckienė, M.; Björk, F. 2011. Owner preferences regarding renovation measures – the demonstration of using multi-criteria decision making, *Journal of Civil Engineering and Management* 17(2): 284–295. <http://dx.doi.org/10.3846/13923730.2011.582380>
- Medineckienė, M.; Turskis, Z.; Zavadskas, E. K. 2011. Life-Cycle analysis of a sustainable building, applying Multi-Criteria Decision Making method, in Čygas, D.; Froehner, K. D. (Eds.). *The 8th International Conference “Environmental Engineering”*: Selected papers. 19–20 May, 2011, Vilnius, Lithuania. Vilnius: Technika, 957–961.
- Mulliner, E.; Smallbone, K.; Maliene, V. 2013. An assessment of sustainable housing affordability using a multiple criteria decision making method, *Omega* 41(2): 270–279. <http://dx.doi.org/10.1016/j.omega.2012.05.002>
- Parasonis, J. 2008. *Basics of buildings structure design*. Vilnius: Technika. 219 p. (in Lithuanian). <http://dx.doi.org/10.3846/997-S>
- Parasonis, J.; Gaudutis, E. 2009. Origin and evolution of high-rise buildings, *Town Planning and Architecture* 33(3): 158–172. <http://dx.doi.org/10.3846/1392-1630.2009.33.158-172>
- Peças, P.; Ribeiro, I.; Silva, A.; Henriques, E. 2013. Comprehensive approach for informed life cycle-based materials selection, *Materials & Design* 43: 220–232. <http://dx.doi.org/10.1016/j.matdes.2012.06.064>
- Qian, Y. M.; Jin, J. Y.; Tian, W. 2012. Research on applying the reborn resource and new materials for energy saving and protecting environment in the design of green ecological residential building design at the super cold district, *Applied Mechanics and Materials* 152–154: 826–834. <http://dx.doi.org/10.4028/www.scientific.net/AMM.152-154.826>
- Ražaitis, V. 2004. *Basics of building construction*. Vilnius: Dailės akademijos leidykla. 325 p. (in Lithuanian).
- Roobahani, A.; Zahraie, B.; Tabesh, M. 2012. PROMETHEE with precedence order in the criteria (PPOC) as a new group decision making aid: an application in urban water supply management, *Water Resources Management* 26(12): 3581–3599. <http://dx.doi.org/10.1007/s11269-012-0091-4>
- Sivilevicius, H. 2011. Application of expert evaluation method to determine the importance of operating asphalt mixing plant quality criteria and rank correlation, *The Baltic Journal of Road and Bridge Engineering* 6(1): 48–58. <http://dx.doi.org/10.3846/bjrbe.2011.07>
- Shen, L.-Y.; Tam, W. Y. V.; Tam, L.; Ji, Y.-B. 2010. Project feasibility study: the key to successful implementation

- of sustainable and socially responsible construction management practice, *Journal of Cleaner Production* 18(3): 254–259.  
<http://dx.doi.org/10.1016/j.jclepro.2009.10.014>
- STR 1.01.06:2002 Technical Construction Regulation “Structures of Exceptional Significance”. Republic of Lithuania, 2002. (in Lithuanian).
- STR 2.02.01:2004 *Technical Construction Regulation “Residential Buildings”*. Republic of Lithuania, 2004. (in Lithuanian).
- Taranath, B. 1998. *Steel, concrete, and composite design of tall buildings*. New York: McGraw-Hill. 1024 p.
- Tupenaite, L.; Zavadskas, E. K.; Kaklauskas, A.; Turskis, Z.; Seniut, M. 2010. Multiple criteria assessment of alternatives for built and human environment renovation, *Journal of Civil Engineering and Management* 16(2): 257–266.  
<http://dx.doi.org/10.3846/jcem.2010.30>
- Turskis, Z.; Zavadskas, E. K.; Peldshus, F. 2009. Multi-criteria optimization system for decision making in construction design and management, *Inžinerine Ekonomika – Engineering Economics* (1): 7–17.
- Yuan, Y.; Yuan, J.; Du, H.; Li, L. 2012. An improved multi-objective ant colony algorithm for building life cycle energy consumption optimization, *International Journal of Computer Applications in Technology* 43(1): 60–66.  
<http://dx.doi.org/10.1504/IJCAT.2012.045842>
- Zavadskas, E. K. 1987. *Complex estimation and choice of resource saving decisions in construction*. Vilnius: Mokslas (in Russian).
- Zavadskas, E. K.; Kaklauskas, A. 1996. *Multiple criteria evaluation of buildings*. Vilnius: Technika. 275 p. (in Lithuanian).
- Zavadskas, E. K.; Kaklauskas, A.; Turskis, Z.; Tamošaitienė, J. 2009. Multi-attribute decision-making model by applying grey numbers, *Informatica* 20(2): 305–320.
- Zavadskas, E. K.; Turskis, Z.; Tamošaitiene, J. 2010. Risk assessment of construction projects, *Journal of Civil Engineering and Management* 16(1): 33–46.  
<http://dx.doi.org/10.3846/jcem.2010.03>
- Zavadskas, E. K.; Kaklauskas, A.; Turskis, Z.; Tamosaitiene, J.; Kalibatas, D. 2011. Assessment of the indoor environment of dwelling houses by applying the COPRAS-G method: Lithuania case study, *Environmental Engineering and Management Journal* 10(5): 637–647.
- Zavadskas, E. K.; Vainiūnas, P.; Turskis, Z.; Tamošaitienė, J. 2012. Multiple criteria decision support system for assessment of projects managers in construction, *International Journal of Information Technology & Decision Making* 11(2): 501–502.  
<http://dx.doi.org/10.1142/S0219622012400135>
- Zuo, J.; Read, B.; Pullen, S.; Shi, Q. 2012. Achieving carbon neutrality in commercial building developments – Perceptions of the construction industry, *Habitat International* 36(2): 278–286.  
<http://dx.doi.org/10.1016/j.habitatint.2011.10.010>

**Jolanta TAMOŠAITIENĖ**. Assoc. Prof., Vice-Dean of Civil Engineering Faculty, Department of Construction Technology and Management at Vilnius Gediminas Technical University, Lithuania. Since 2013 she is a member of Editorial Board of the Journal of Engineering, Project, and Production Management”, since 2011 she is a member of Editorial Board of the Journal, Technological and Economic Development of Economy”, since 2009 she is a member of EURO Working Group OR in Sustainable Development and Civil Engineering, EWG-ORS DCE. She published more than 50 scientific papers. Research interests: civil engineering, many miscellaneous management areas (enterprise, construction project and etc.), risk assessment, construction project administration, building life-cycle, construction technology and organisation, decision-making and grey system theory, decision making (DM), statistics, optimization, strategies, game theory, intelligent support system, sustainable development: developing of alternative construction processes, economic and other aspects, sustainable development challenges for business and management in construction enterprises, environmental impact processes and etc.

**Ernestas GAUDUTIS**. PhD student, Department of Architectural Engineering, Vilnius Gediminas Technical University (VGTU), Saulėtekio al. 11, LT-10223 Vilnius, Lithuania. MSc (2007) from VGTU. Author and co-author of 5 scientific articles and 1 study book.